

See discussions, stats, and author profiles for this publication at: <https://www.researchgate.net/publication/286667594>

The comparative analysis of boost DC/DC converter used in hybrid electric vehicles

Article · October 2012

CITATIONS

2

READS

24

3 authors, including:



Murat Tuna

Kirklareli University

29 PUBLICATIONS 77 CITATIONS

SEE PROFILE

The comparative analysis of boost DC/DC converter used in hybrid electric vehicles

Murat Tuna^{1,*}, Ayse Ergun Amac², Muhlis Ak³

¹Kirklareli University, Technical Education Faculty, Department of Electrical Education Kirklareli, Turkey

²Kocaeli University, Technical Education Faculty, Department of Electrical Education Kocaeli, Turkey

³Elimsan switchgear and electromechanical San. and Tic. Co. Uzuntarla Kocaeli, Turkey

Received: 24 December 2011; accepted: 13 April 2012

Abstract

Power electronics converters are the periodically changing systems because of their switching structures. For this reason, the dynamic attitudes of the converters show nonlinear characteristics. The analysis and design of such types of systems are quite difficult. In this case, modelling and analogy become one of the most important elements of the analysis and design processes of power electronics circuits. The generalized state space averaging method (GSSA) converts the nonlinear equations of the system into linear state space system. This method is based upon Fourier conversion. Thus, the system becomes linearized. Thanks to this method, the relation between the state equations of the system can be explained with linear equations. In this study, the analogy results obtained through using GSSA method for boost DC/DC converter used in hybrid electric vehicles (HEV) have been compared with the real time analogies implemented with PSIM program and the results taken from the well known state space averaging (SSA) method, and the validity of the suggested method has been proved.

Keywords: Generalized State Space Averaging Method (GSSA), DC/DC Boost Converters; Hybrid electric vehicles

©Sila Science. All rights reserved.

1. Introduction

Hybrid electric vehicles (HEV) have been defined as a vehicle where energy is provided by two or more sources of energy and at least one of these sources of energies provides electric energy. These vehicles consist of fuel-injection engine, battery, super condenser and fuel cell units.

In the applications of hybrid electric vehicles, in order to connect the systems connected to different voltage level (fuel cell, battery group or electric circuits needing low voltage feed and etc.) to each other and to control DC motor, generally DC/DC converters are used [1].

*Corresponding author. Tel.: +90-288-246-1666; fax: +90-288-246-1650.
E-mail address: murat.tuna@kirklareli.edu.tr (Murat Tuna).

In the modeling of DC/DC converters, various analogy programs (MATLAB, PSIM, PSPICE, etc.) or conventional mathematical methods (State Space Averaging-SSA) are used. That the analogy programs need wide computer sources and long simulation times has made the conventional averaging methods advantageous. For, this methods is faster than the switching models and it does not need a lot of computer sources. However, the conventional averaging models don't follow fast and big signal acts [2-3].

In this study, in the modelling of an ideal boost DC/DC converter connected to the output of a fuel cell, generalized state space averaging (GSSA) that eliminates the disadvantages of the conventional state space averaging method has been used. In this method, the average of harmonic state variables is also taken into account.

2. GSSA method and boost dc/dc converter

The parallel connection relationship of different level DC voltages used in hybrid electric vehicles with vehicle voltage bus was given in Fig. 1.

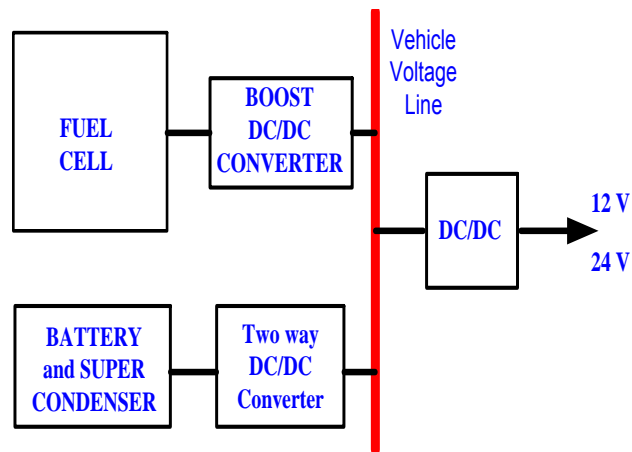

Fig. 1. Power system in hybrid electric vehicles.

Here, to connect fuel cell to bus, boost DC/DC converter also called power direction system has been used. The converter also provides the regulation of fuel cell output voltage which is in the state of nonideal power supply.

In Fig. 2, T_s switching period which connects fuel cell to vehicle and is in the mode of continuous conduction (CCM), and PWM running on d duty circuit and boost DC/DC converter are shown.

The generalized state space averaging method was drawn out of Fourier conversion for nonperiodical signals. This method is based upon the principle of “it can be approached by arbitrary accuracy using the coefficients of Fourier conversion which is in the form of $x(t)$ wave and in the time interval of $(t-T, T]$ ending” [2-6]. This connection is calculated with;

$$x(t) = \sum_{k=-n}^n \langle x \rangle_k(t) e^{jk\omega t} \tag{1}$$

$$\langle x \rangle_k(t) = \frac{1}{T} \int_{t-T}^t x(\tau) e^{-jk\omega\tau} d\tau \tag{2}$$

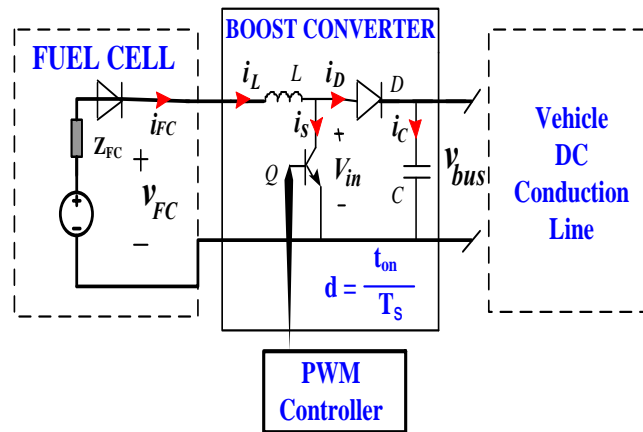

Fig. 2. DC/DC boost converter with PWM, ($v_{in}=20\text{ V}$, $R_o=10\Omega$, $L=1\text{ mH}$, $C=50\text{ }\mu\text{F}$, $T_s=0.1\text{ ms}$).

Here, $\langle x \rangle_k(t)$ are complex Fourier coefficients. In (1), the value of n depends on the degree of accuracy. If the infinite n is omitted here, the mistake of approach also declines to zero. If a state variable doesn't have any oscillation and is also stable, the result obtained through only using $k=0$ term gives the result attained via state space averaging method. Besides this, if a state variable has only one oscillation similar to sinewave, the term of $k=1,1$ is used. This method is named the first harmonic approach. If a state variable has a DC value and also an oscillation, the term of $k=-1, 0, 1$ is used. Here the more term is considered, the more one gets close to accuracy [4-5-6].

So as to apply generalized state space averaging method, firstly switching function $u(t)$ is determined. The switching function shown in Fig. 3 is connected to the circuit switching control which decides the change of circuit topology according to time.

$$u(t) = \begin{cases} 1, & 0 < t < dT \\ 0, & dT < t < T \end{cases} \tag{3}$$

$$V_{in} = (1 - u(t)) \cdot v_o \tag{4}$$

$$i_D = (1 - u(t)) \cdot i_L \tag{5}$$

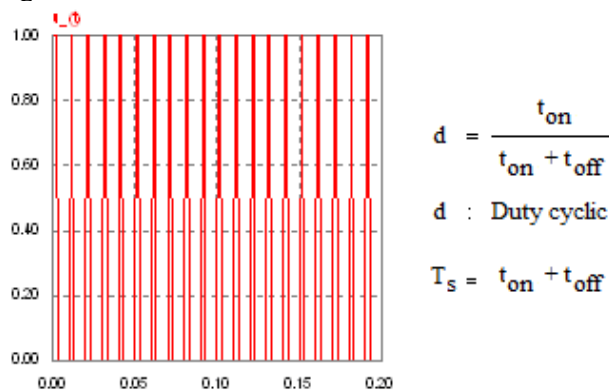

Fig. 3. Switching function $u(t)$.

3. The application of GSSA method to the suggested converter

In the boost DC/DC converter circuit operating always in conduction mode, when the switching equation sets in (4-5) are applied to combined state variables;

$$\frac{di_L}{dt} = \frac{1}{L} [v_{in} - (1 - u(t) \cdot v_o)] \tag{6}$$

$$\frac{dv_o}{dt} = \frac{1}{C} [(1 - u(t)) i_L - i_R] \tag{7}$$

$$i_{in} = i_L \tag{8}$$

state space equations are obtained. In the equations sets of the generalized state space averaging model, the current state space variables are the Fourier coefficients of circuit state variables (v_o ve i_L). When the first harmonic approach is applied to the Fourier coefficients of this system's state variables;

$$i_L = \langle i_L \rangle_{-1} e^{-j\omega t} + \langle i_L \rangle_0 + \langle i_L \rangle_1 e^{j\omega t} \tag{9}$$

$$v_o = \langle v_o \rangle_{-1} e^{-j\omega t} + \langle v_o \rangle_0 + \langle v_o \rangle_1 e^{j\omega t} \tag{10}$$

equations are got. Here ω is the basic frequency of the circuit. In order to find out the $i_L(t)$ ve $v_o(t)$ variables,

$$\langle i_L \rangle_1 = x_1 + jx_2 \tag{11}$$

$$\langle i_L \rangle_0 = x_5 \tag{12}$$

$$\langle v_o \rangle_1 = x_3 + jx_4 \tag{13}$$

$$\langle v_o \rangle_0 = x_6 \tag{14}$$

$$\langle i_L \rangle_{-1} = \langle i_L \rangle_1^* \tag{15}$$

$$\langle v_o \rangle_{-1} = \langle v_o \rangle_1^* \tag{16}$$

six real state variables ($x_1, x_2, x_3, x_4, x_5, x_6$) are designated. Here (*) operator means the conjugate of a complex number. If the designated state variables are written in their places in the equations (9) and (10);

$$i_L(t) = x_5 + 2x_1 \cos \omega t - 2x_2 \sin \omega t \tag{17}$$

$$v_o(t) = x_6 + 2x_3 \cos \omega t - 2x_4 \sin \omega t \tag{18}$$

is obtained. When the Fourier coefficient analysis (2) of switching function $u(t)$ is carried out;

$$\langle u(t) \rangle_0 = d \tag{19}$$

$$\langle u(t) \rangle_1 = \frac{\sin 2\pi d + j(\cos 2\pi d - 1)}{2\pi} \tag{20}$$

is obtained. Later to the state variables in (6-8) of the circuit were applied the Fourier conversion coefficients state variables' derivatives against time and the conversions of their multiplication. At the same time, by putting switching $u(t)$ in the places of Fourier coefficients, GSSA model of boost DC/DC converter was drawn. To find the unknown variables in the obtained GSSA model, matrix numbered (21) is used. This matrix can be easily solved with a software like MATLAB.

$$\begin{bmatrix} \dot{x}_1 \\ \dot{x}_2 \\ \dot{x}_3 \\ \dot{x}_4 \\ \dot{x}_5 \\ \dot{x}_6 \end{bmatrix} = \begin{bmatrix} 0 & \omega & -\frac{1-d}{L} & 0 & 0 & \frac{\sin 2\pi d}{2\pi L} \\ -\omega & 0 & 0 & -\frac{1-d}{L} & 0 & \frac{-\sin^2 \pi d}{\pi L} \\ \frac{1-d}{C} & 0 & -\frac{1}{RC} & \omega & \frac{-\sin 2\pi d}{2\pi C} & 0 \\ 0 & \frac{1-d}{C} & -\omega & -\frac{1}{RC} & \frac{\sin^2 \pi d}{\pi C} & 0 \\ 0 & 0 & \frac{\sin 2\pi d}{\pi L} & \frac{-2.\sin^2 \pi d}{\pi L} & 0 & \frac{-1-d}{L} \\ \frac{-\sin 2\pi d}{\pi C} & \frac{2.\sin^2 \pi d}{\pi C} & 0 & 0 & \frac{1-d}{C} & -\frac{1}{RC} \end{bmatrix} \begin{bmatrix} x_1 \\ x_2 \\ x_3 \\ x_4 \\ x_5 \\ x_6 \end{bmatrix} + \begin{bmatrix} 0 \\ 0 \\ 0 \\ 0 \\ \frac{V_{in}}{L} \\ 0 \end{bmatrix} \tag{21}$$

By placing the real state variables obtained in the solution of Matrix in their places in (17) and (18) equations, the current-voltage values of the circuit are found.

4. The comparison of GSSA with conventional methods

The results of GSSA model implemented for boost DC/DC converter were compared with the analogy results obtained from SSA model. Besides, so as to demonstrate the validity of the analogy results of GSSA method, the results of real time analogy carried out in the PSIM program were analyzed.

The analogy results of boost converter at different duty circuit ($d = 0.25$ and 0.5) values attained through PSIM and GSSA methods were shown in Figs. (4-6), respectively. It is also understood from the figures that state space averaging method (SSA) which is used in modeling DC/DC converters mathematically has remained inadequate. Yet, how similar is GSSA model to PSIM model is seen. Furthermore, it is seen that $k=0$. approach model gives the same results with SSA model.

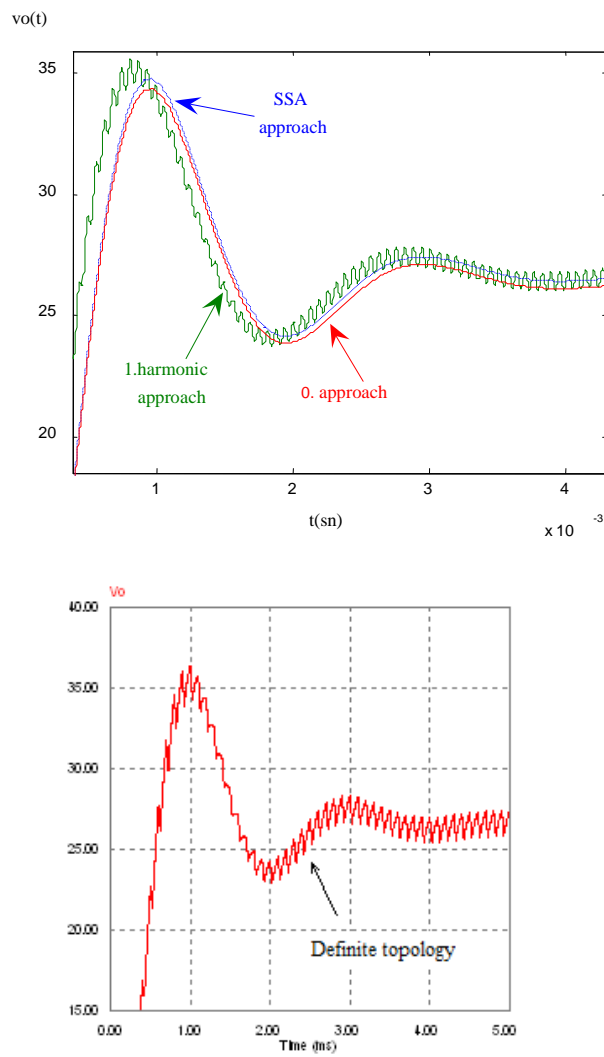
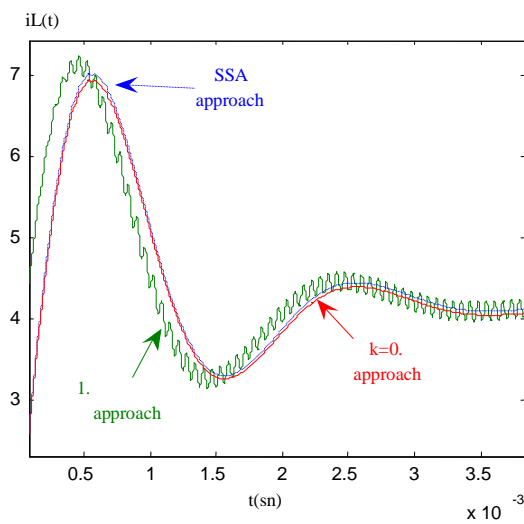

Fig. 4. Output voltage wave shapes for $d=0.25$, upper: SSA and GSSA approaches, bottom: PSIM analogy results.



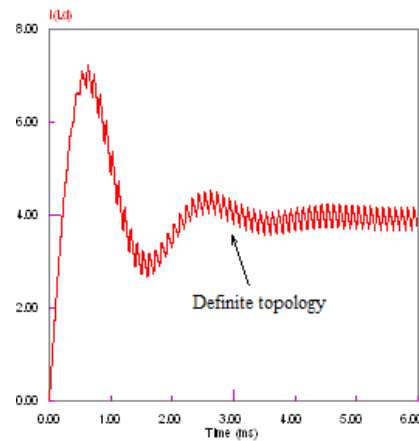

Fig. 5. Load current wave shapes for $d = 0.25$, upper: SSA and GSSA approaches, bottom: PSIM analogy results.

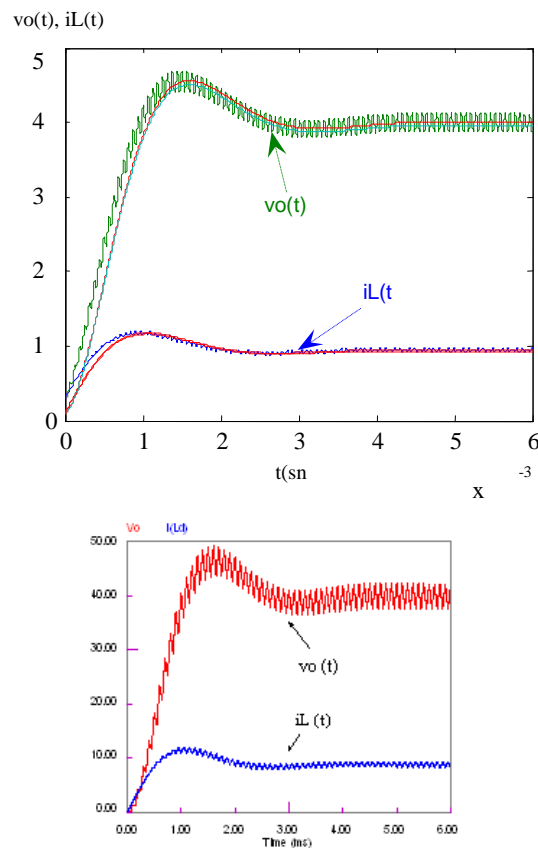

Fig. 6. Load current-voltage wave shapes for $d=5$, upper: SSA and GSSA approaches, bottom: PSIM analogy results.

4. Results and conclusions

The power electric converters are such circuits as coil, condenser, resistance, thyristor, IGBT, mosfet, diode which have switching and passive elements [10-12]. These converters show characteristics of which dynamic attitudes are nonlinear because of their switching structures. In this case, simulation and modelling become one of the most important elements of analysis and design processes. These provide great benefits to the designer in understanding the system. However, the existing models are not used in obtaining big signal

distortions and estimating harmonic components. Yet, with GSSA method, these problems have been overcome. This method is based on Fourier conversion. In this way, the system is made linear. Thus, the relationship between the state equations of the system is expressed with linear equalities.

In this study, the real time analogy achieved with PSIM, and the boost DC/DC converter analogy results attained with state space averaging (SSA) and generalized state space averaging (GSSA) methods have been compared. Using GSSA model, the big signal model of the system was drawn and the harmonic characteristics of the whole system parameters were attained.

As a consequence of the comparisons, it has been observed that GSSA method gives perfect result in the basic DC/DC converters. In this method, the more terms of k we take into account, the more we get close to exact topology (real time) results.

References

- [1] Unlu N, Karahan S, Tur O, Ucarol H, Ozsu E, Yazar A, Akgun F, Tiris M. "Electric Vehicles". TUBITAK- Marmara Research Center Energy Systems and Environmental Research Institute, Gebze-Kocaeli, September 2003.
- [2] Mahdavi J, Emadi A, Bellar MD, Ehsani M. "Analysis of Power Electronic Converters Using the Generalized State Space Averaging Approach," in Proc. IEEE Trans. On Circuits and Systems I: Fundamen Theory Appl 1997;44:767–770.
- [3] Sanders SR, Noworolski JM, Liu XZ, Verghese GC. Generalized Averaging Method for Power Conversion Circuits. In Proc. IEEE Trans Power Elect 1991;6:251–259.
- [4] Emadi A. Modelling and Analysis of Multi-Converter DC Power Electronic Systems Using the Generalized State Space Averaging Method," in Proc. IEEE Trans Ind Elect 2004;51:661–668.
- [5] Krein PT, Bentsman J, Bass RM, Lesieutre B. "On the Use of Averaging for the Analysis of Power Electronic Systems," in Proc. IEEE Trans Power Electr 1990;5:182–190.
- [6] Altınay M, Amac EA, Karakas E. Ideally a DC/DC Buck converter Modeling of Generalized State Space Average Method. I. Symposium on Energy Efficiency and Quality, Kocaeli, May 2005.
- [7] Wang CH, Chen Y, Huang J. Thermal and electrical mechanism of thermoelectric generation chip and its performances in solar energy thermal power system. *Energ Educ Sci Tech-A* 2011;28:331–338.
- [8] Senel Coruhlu T, Calik M, Cepni S. Effect of conceptual change pedagogies on students' alternative conceptions of electricity resistance and electricity current. *Energ Educ Sci Tech-B* 2012;4:141–152.
- [9] Jia Z. Nickel hydroxide sulfate nanobelts: Hydrothermal synthesis, electrochemical property and conversion to porous NiO nanobelts. *Energ Educ Sci Tech-A* 2012;29:811–818.
- [10] Khan MAR, Rahman MM, Kadirgama K. Artificial neural network model for material removal rate of TI-15-3 in electrical discharge machining. *Energ Educ Sci Tech-A* 2012;29:1025–1038.
- [11] Akinci TC, Dursun E, Seker S, Kilic O. Coherence analysis between hydrogen flow and electricity current in fuel cells. *Energ Educ Sci Tech-A* 2012;28:555–562.
- [12] Guo J, Qin C, Ma F, Tong C. Exhaust emissions and electric energy generation in a stationary engine using blends of biogas and natural gas. *Energ Educ Sci Tech-A* 2012;29:193–200.